

Small Sype R.O. Deionizer

Model: TC-020-SRO



T&C Technical



Features

- ★ Water quantity 20L/h
- ★ Simple maintenance
- ★ Compact size (Wall mounting)
- ★ Direct through tap water faucet

Application

Chemical analysis water

Humidifying water

Washing water

Rinsing water

Drinkable water

Ultra-pure water



Drinking water



Cooking water



Humidifying water for air conditioner



Direct through tap water faucet (Using multi-cock)

Manufacturing Process

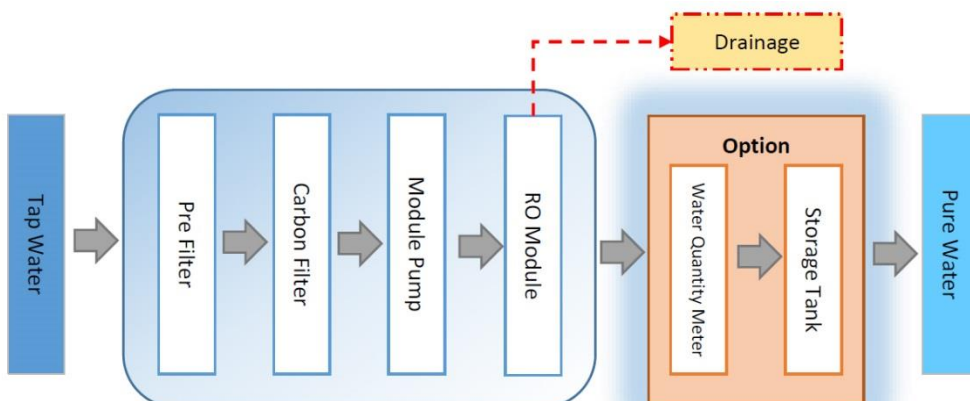

90~99% of inorganic & organic substance, micro organic of raw water is efficiently eliminated.

■ Specifications

Model	TC-020-SRO
Water quantity	Temperature of water 25°C 20 (L / hr)
	Temperature of water 10°C 11 (L / hr)
Elimination efficiency	90 ~ 99 (%)
External dimensions	W400 × D180 × H460 (mm)
R.O. module	2 module
Pre-filter	10 inch wind filter × 1
	10 inch carbon filter × 1
Production Supply / Drain outlet	Rc 1/4
Power supply voltage	AC200V 50/60Hz 2A

■ Measurement (mm)

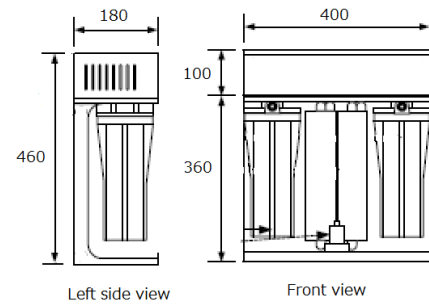

■ Condition of feed water

Water pressure (during operation)	0.1 ~ 0.5 MPa
Water temperature	5 ~ 35°C
Raw water	Tap water
Total hardness	< 50mg CaCO ₃ / L
Silica	< 30mg / L

※ It could be especially necessary for installation of pre-treatment apparatus and decompression valve if condition of feed water deviates.

■ Option and Accessories

A variety of option as water storage tank, water quality meter, and UV sterilization lamp are available.



Water quality meter



Water pressure tank
10L 40L



Chemical tank
10L 20L



UV sterilization lamp



Desk top type
ion-exchanger deionizer